



**DESCRIPTIONS:**

FW500 series offers a large stainless steel tray and IP69K waterproof design, which is perfectly protected from high pressure and high temperature washing. The scale is ideal for wet and hygienic circumstances such as fish market, food manufacturing and feeding facilities

**MAIN FEATURES:**

- IP69K (Waterproof)
- Large stainless steel tray
- Fast and accurate weighing operation (1/3,000 dual interval)
- Auto-Power OFF
- Bright and large display



**OPTIONS:**

- Rear display

**SPECIFICATIONS:**

Model	FW500-C			FW500-E		
Capacity	3/6 Kg	6/15Kg	15/30Kg	3/6 Kg	6/15Kg	15/30Kg
Readability	1/2 g	2/5 g	5/10 g	1/2 g	2/5 g	5/10 g
Resolution	1/3,000 (Dual Interval)					
Resolution	1/3,000 – 1/30,000					
Display	LCD			LED		
Status	Stable, Zero, Tare, Unit, BAT					
Key	Zero, Tare, Hold, Power					
Function	Hold, Auto-Power OFF					
Power	Dry battery (D size 1.5V x 4ea) 12V/1.5A Adaptor			6V rechargeable battery 12V/1.5A Adaptor		
Battery life	Manganese dry battery: 1200hrs Alkaline dry battery: 2500hrs			Rechargeable battery: 100hrs		
Operating Temp.	-10°C – +40°C					
Dimensions	266x303x109 mm					
Platter size	247x212 mm					

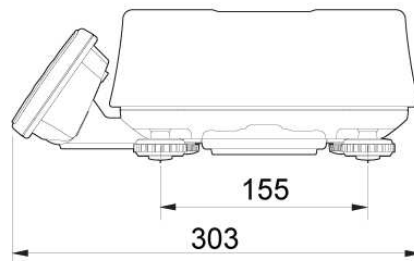
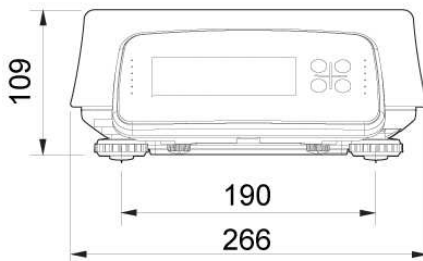
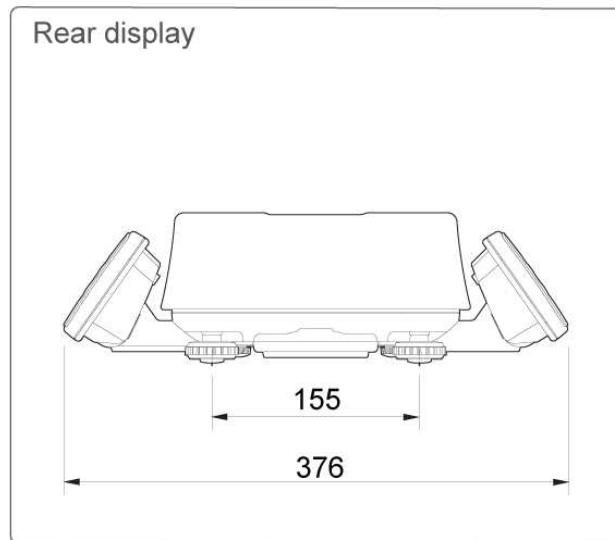
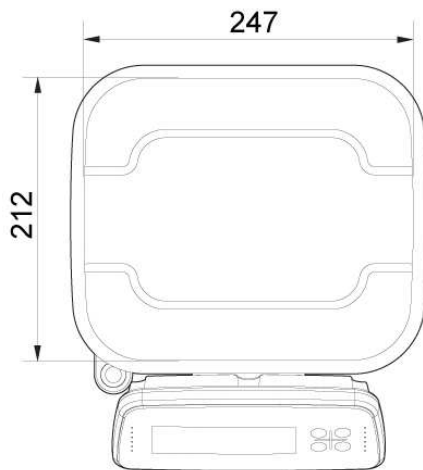
**DIMENSIONS:**

Global Measurement Srl  
 Via Olona 183/N, 21013 Gallarate (VA)  
 Tel: 0331/786999 Fax: 0331/213964  
 info@global-measurement.it www.global-measurement.it