



DESCRIPTIONS:

Portable bench scale equipped with a large LCD display which is also detachable for easy viewing. The GM-PB is able to be connected to Ticket/Label printers or a PC via RS232 interface.

APPLICATIONS:

- Home deliveries companies
- Farm productions
- Dried fish
- Fruit & vegetables
- Meat processing companies
- Hospitals
- Schools and fitness center



MAIN FEATURES:

- Easy to carry
- Available capacity: 30 ~ 200Kg
- Detachable LCD display
- RS232 interface
- White Backlight
- Battery operated (rechargeable)
- Up to 300 hours of continuous use
- Auto power off
- Auto Zero tracking



SPECIFICATIONS:

Model	GM-PB Series			
Capacity	30Kg	60Kg	150Kg	200Kg
Readability	5/10g	10/20g	20/50g	50/100g
External resolution	1/2000 ~ 1/3000 (Dual interval)			
Display	6digit LCD			
Operating Temp.	-10°C ~ +40°C			
Battery life	Alkaline battery: 300hs/140hrs Rechargeable battery: 60hrs/25hrs			
Power	Battery or AC adapter			
Dimensions	355x611x55 mm			
Platter size	355x443 mm			

CUSTOMIZED LOGO & COVER DESIGN:



Global Measurement Srl
Via Olona 183/N, 21013 Gallarate (VA)
Tel: 0331/786999 Fax: 0331/213964
info@global-measurement.it www.global-measurement.it

DIMENSIONS:

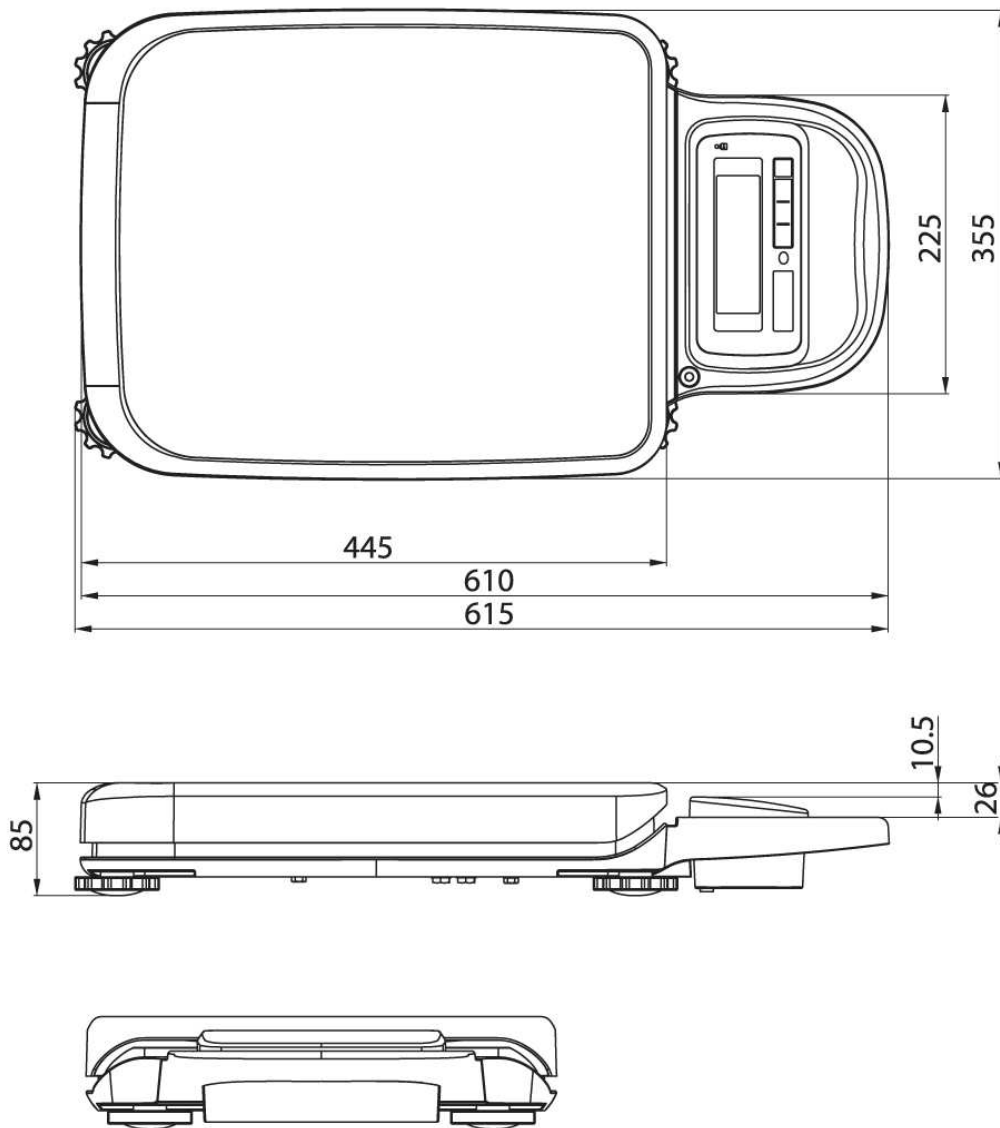

Global Measurement Srl
Via Olona 183/N, 21013 Gallarate (VA)
Tel: 0331/786999 Fax: 0331/213964
info@global-measurement.it www.global-measurement.it