



DESCRIPTIONS:

RW-S/L is designed for mobile weight inspection, heavy duty cast aluminium construction.

- 1 inch LCD illuminated backlight display
- Used for cars, trucks and customs applications
- Battery operated with AC adapter/charger
- Single and double width available
- Scales are linkable for multi-axle weighing (up to 6 scales)

MAIN FEATURES:

- Multi-Axle weighing
- Kg/lb switchable
- Displays individual or total weight
- Advanced digital filtering to compensate for vibration

APPLICATIONS:

- Safeguards against overloaded vehicles
- Mobile weight inspections

DISPLAY & KEY PAD:



OPTIONS:

- Totalizer cable
- Printer

SPECIFICATIONS:

Model	RW-05S	RW-10S	RW-05L	RW-10L
Capacity	5000 Kg	10000 Kg	5000 Kg	10000 Kg
Readability	2 g	5 g	2 g	5 g
Display	5 digit LCD display			
Accuracy	1%			
Safe Oveload	150%			
Operating Time	20hrs (charging time 8hrs)			
Power	1.5V AA size 12EA DC7.2V 2.6Ah battery AC 110V/220V charger			
Pads dimensions	309x340 mm		624.8x340 mm	
Operating Temp.	-10°C – +40°C			
Dimensions	536x458x60 mm		566x718x60 mm	

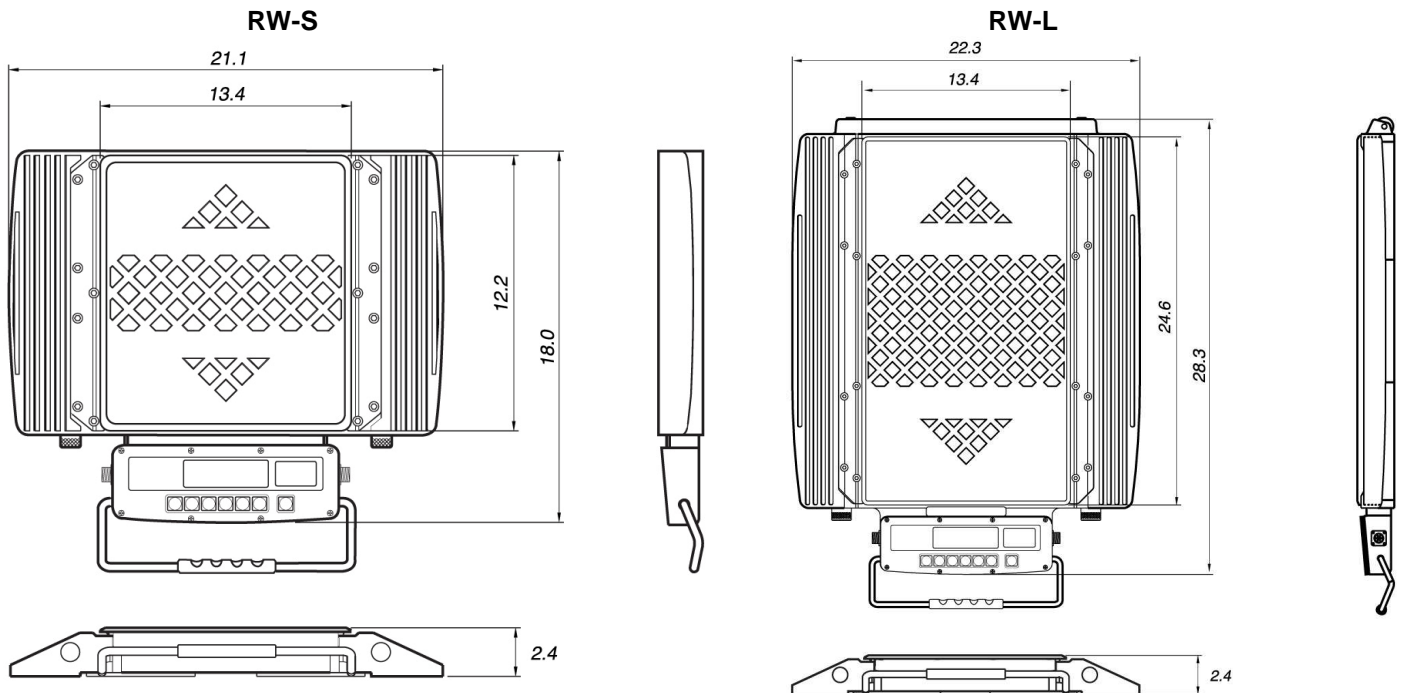
DIMENSIONS:

Global Measurement Srl
 Via Olona 183/N, 21013 Gallarate (VA)
 Tel: 0331/786999 Fax: 0331/213964
info@global-measurement.it www.global-measurement.it