



**APPLICATIONS:**

- Open market
- Farm
- Industrial environment

**MAIN FEATURES:**

- High resolution for weighing (max. 1/30000; certificate 1/3000 dual)
- Easy grab body, ergonomics design with a low body and comfortable handling
- USB port for COMM. & power option
- Rechargeable battery (max. 1000 hours when used with Mn or Pb battery together)
- Rear display for customers

**OPTION:**

- RS232
- USB port
- SUS tray

**OPTION:**

- Hold
- Unit conversion
- Counting-counting sample range: 10-100-200-300-400-500
- Weight comparison function: HI/OK/LOW
- Sleep mode function

**SPECIFICATIONS:**

Model	SW-II-03	SW-II-06	SW-II-15	SW-II-30
Capacity	3Kg	6Kg	15Kg	30Kg
e	0.5/0.2/0.1(g) 1/0.5 (Certi)	1/0.5/0.2(g) 2/1 (Certi)	2/1/0.5(g) 5/2 (Certi)	5/2/1(g) 10/5 (Certi)
Resolution	1/30000; certificate 1/3000 dual	1/30000; certificate 1/3000 dual	1/30000; certificate 1/3000 dual	1/30000; certificate 1/3000 dual
Display	6digit LCD (115x39.5mm) & Backlight			
Symbols	Stable, zero, tare,g,kg,lb,oz,pcs,low bat, hi/ok/low & pcs			
Keys	Zero, tare, mode, function key, zero/unit, tare/hold, mode, fn			
Operating Time	Approx D size battery = 500hr or pb battery = 450hr (backlight off) Approx. 1000hr consecutively when equipped with Mn battery and Pb battery together			
Power	1.5V x 3 units (D size battery) or Pb batter 4Ah or 6V adapter			
Dimensions	245x280x110 mm			
Platter size	225x190 mm			

**DIMENSIONS:**

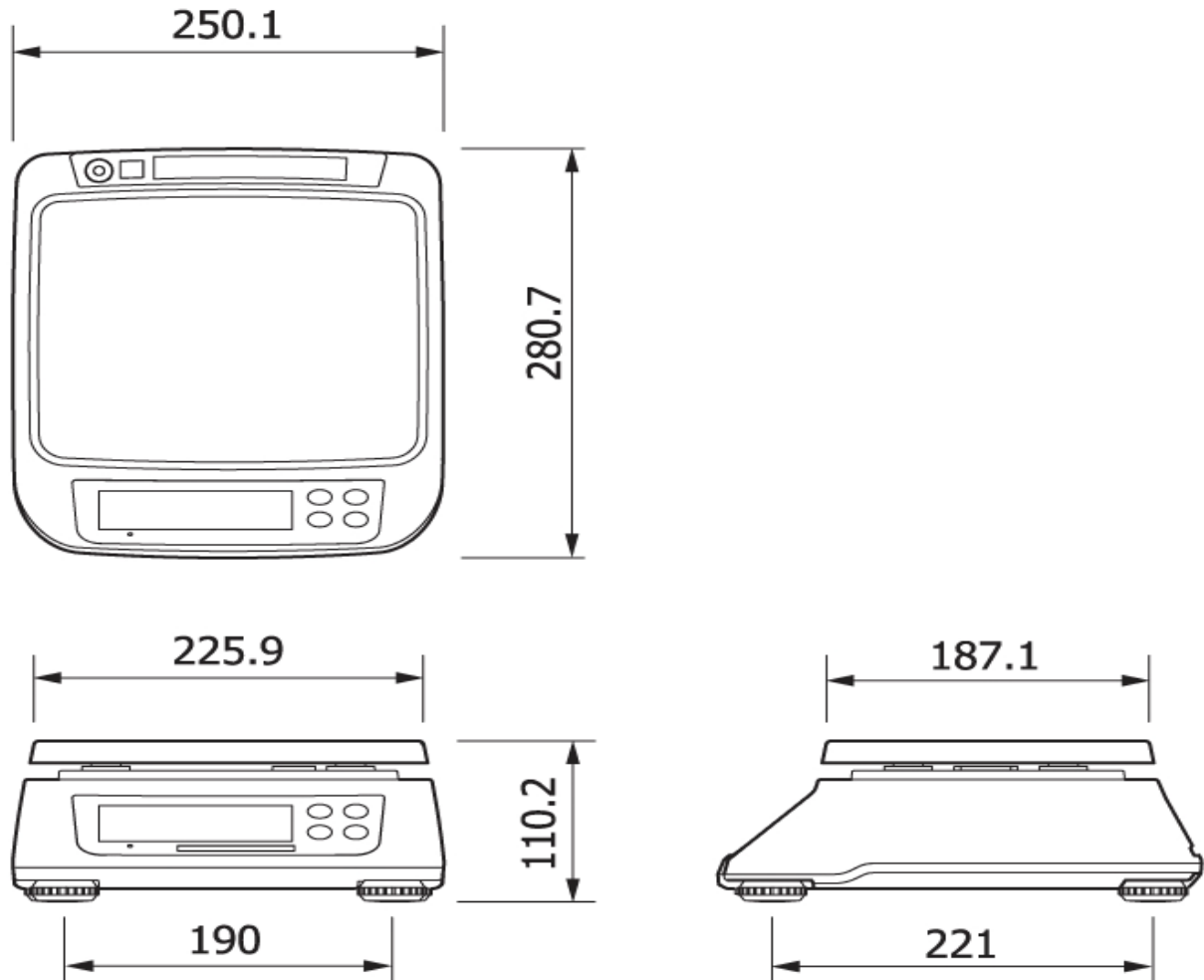

Global Measurement Srl  
 Via Olona 183/N, 21013 Gallarate (VA)  
 Tel: 0331/786999 Fax: 0331/213964  
 info@global-measurement.it www.global-measurement.it