

GENERAL SPECIFICATIONS:

- Display: 25mm digit LCD display, with white LED backlight
- Capacities: 3Kg – 30Kg
- Pan size: 204x263mm
- Keyboard: 2keys (membrane keyboard)
- Housing: ABS plastic
- Max. Divisions: 3000e; 2x3000e; 30000d; 60000d
- ADC: sigma delta
- ADC update: ≤1/10 sec.
- Operate Temp.: -10°C~+40°C
- Power: AC adapter (12V/500mA), internal rechargeable battery (6V/3.2Ah)



MAIN FEATURES:

- Stainless steel pan
- OIML Approval from Delta (approval n.: 0200-NAWI-03407)
- Battery provides up to 60 hours of continuous use
- Optional RS232 can connect to PC or label print
- Optional rear display
- Optional First Verification

SPECIFICATIONS:

Model Name	Capacity	Readability	Division	Approx. Weight	Approval
ZHW-3K	3Kg	0.1g	30000e	4.1Kg	CE
ZHW-6K	6Kg	0.2g	30000e	4.1Kg	CE
ZHW-15K	15Kg	0.5g	30000e	4.1Kg	CE
ZHW-30K	30Kg	1g	30000e	4.1Kg	CE
ZHW±3K	3Kg	0.05g	60000e	4.1Kg	CE
ZHW±6K	6Kg	0.1g	60000e	4.1Kg	CE
ZHW±15K	15Kg	0.2g	60000e	4.1Kg	CE
ZHW±30K	30Kg	0.5g	60000e	4.1Kg	CE
ZHW-3K-M	3Kg	1g	3000e	4.1Kg	CE, OIML
ZHW-6K-M	6Kg	2g	3000e	4.1Kg	CE, OIML
ZHW-15K-M	15Kg	5g	3000e	4.1Kg	CE, OIML
ZHW-30K-M	30Kg	10g	3000e	4.1Kg	CE, OIML
ZHW-6K-MR	6Kg	1/2g	2x3000e	4.1Kg	CE, OIML
ZHW-15K-MR	15Kg	2/5g	2x3000e	4.1Kg	CE, OIML
ZHW-30K-MR	30Kg	5/10g	2x3000e	4.1Kg	CE, OIML

DIMENSIONS:

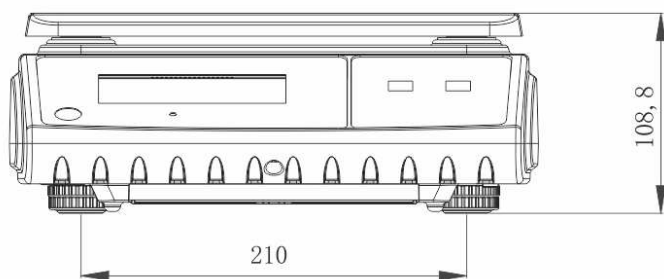
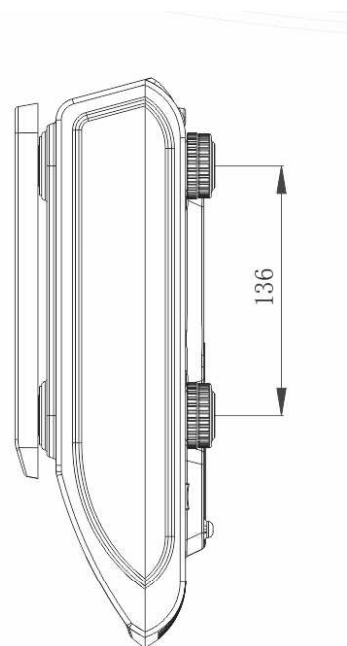
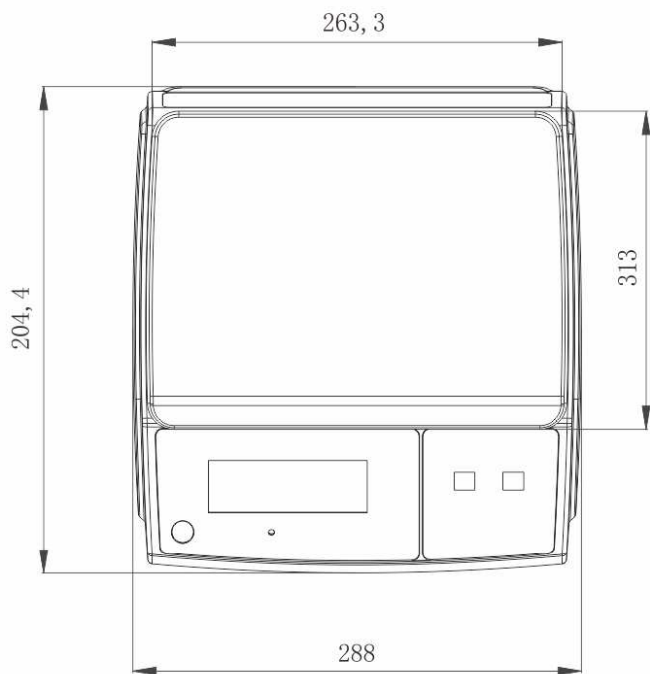

Global Measurement Srl
Via Olona 183/N, 21013 Gallarate (VA)
Tel: 0331/786999 Fax: 0331/213964
info@global-measurement.it www.global-measurement.it